



Codice
Code

V1PL2N03040

Materiale: Polietilene reticolato (XLPE)
Material: Crosslinkable polyethylene

Provisti di: • Tappo di riempimento / sfiato con filtro e sistema frangiolio
• indicatore di livello

Equipped with: • Emptying hole and G 3/4 cap on the bottom
• oil level indicator

Capacità
Capacity 30 lt

Peso
Weight 4,5 Kg

Colore
Color nero
black

Temperatura di utilizzo Working temperature	-20 ÷ 80°C
Oli minerali Mineral oil	HH - HL - HM - HR - HV - HG
Resistenza UV UV resistance rate	UV-8 (ASTM D2565)

Ingombro serbatoio / Tank dimensions

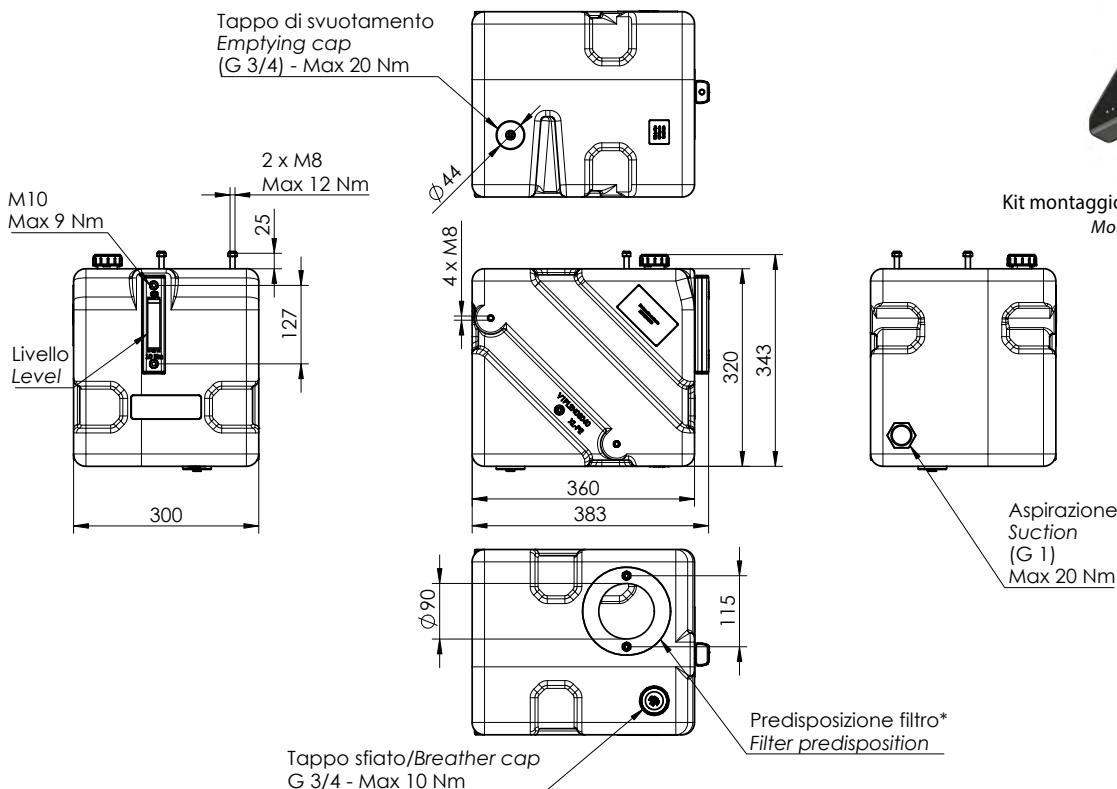

Kit montaggio (da ordinare separatamente)
Mounting kit (To be order separately)
135903P2LN0
[Istruzioni di montaggio](#)
[Mounting instructions](#)

Optional *



Flangia / Flange F
Filtri flangiabili / Flangible filters
118001

Collegamenti / Link:
[Accessori / Accessories](#)



Livello olio colonna
Oil level
50900400230



Tappo sfiato
Breather cap
50900500211